



PROTOCOL CONVERTERS

IMPORTANT NOTES

- Convert input control signals (DMX or DALI) to 0/1-10V signals to control LED drivers
- Have the capacity to control a large number of LED drivers (eg. 70 per channel)
- Are well suited for large areas where many Cooledge TILES are controlled as a single illuminated surface
- May be used for dimming and/or tuning CCT for TILE Premium products
- Enable one-way communication from a DMX/DALI controller to the drivers. RDM or DALI diagnostics are not possible when converting these protocols to a 0/1-10V signal.
- Operate at 12-24 VDC through separate power supply (typ. Maximum power consumption = 6W)

PROTOCOL CONVERTERS FOR DIMMING

- For use with TILE Standard, TILE Plus, and LINE products for dimming control
- Allows the use of standalone DMX/DALI based dimmers or connection to a central DMX/DALI controller
- One DMX or DALI address (channel) converts to one 0-10V (1-10V) dimming channel
- One converter channel may operate a large number of LED drivers when all of the TILES or LINES are to be dimmed simultaneously as a group or zone

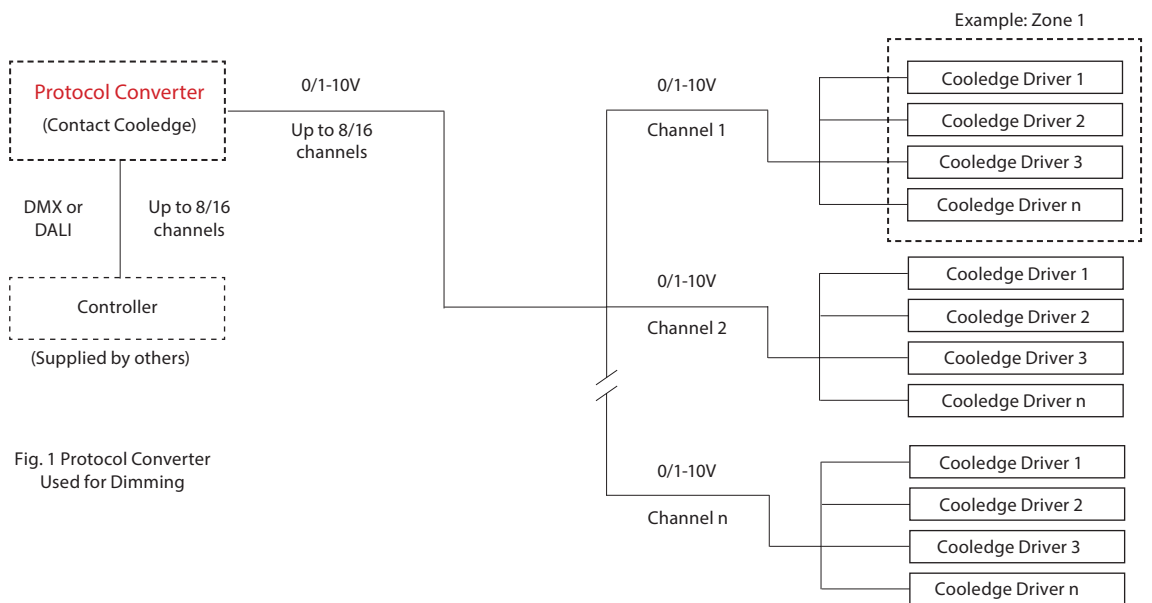

Fig. 1 Protocol Converter Used for Dimming

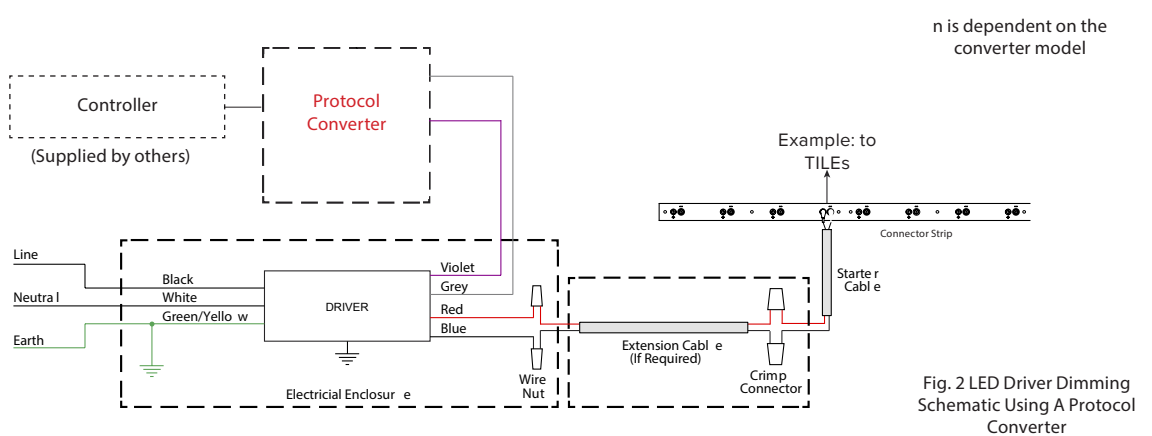

Fig. 2 LED Driver Dimming Schematic Using A Protocol Converter

PROTOCOL CONVERTERS FOR DIMMING + CCT TUNING

- For use with TILE Premium products for tunable white and dimming control
- Allows the use of standalone DMX/DALI based controllers or connection to a central DMX/DALI controller
- Two DMX/DALI channels are needed for each driver group or zone:
 - One DMX or DALI address (channel) converts to one 0-10V (1-10V) CCT tuning signal
 - One DMX or DALI address (channel) converts to one 0-10V (1-10V) dimming signal
- One converter channel may operate a large number of LED drivers when all of the Premium TILES are to change CCTs or dim simultaneously

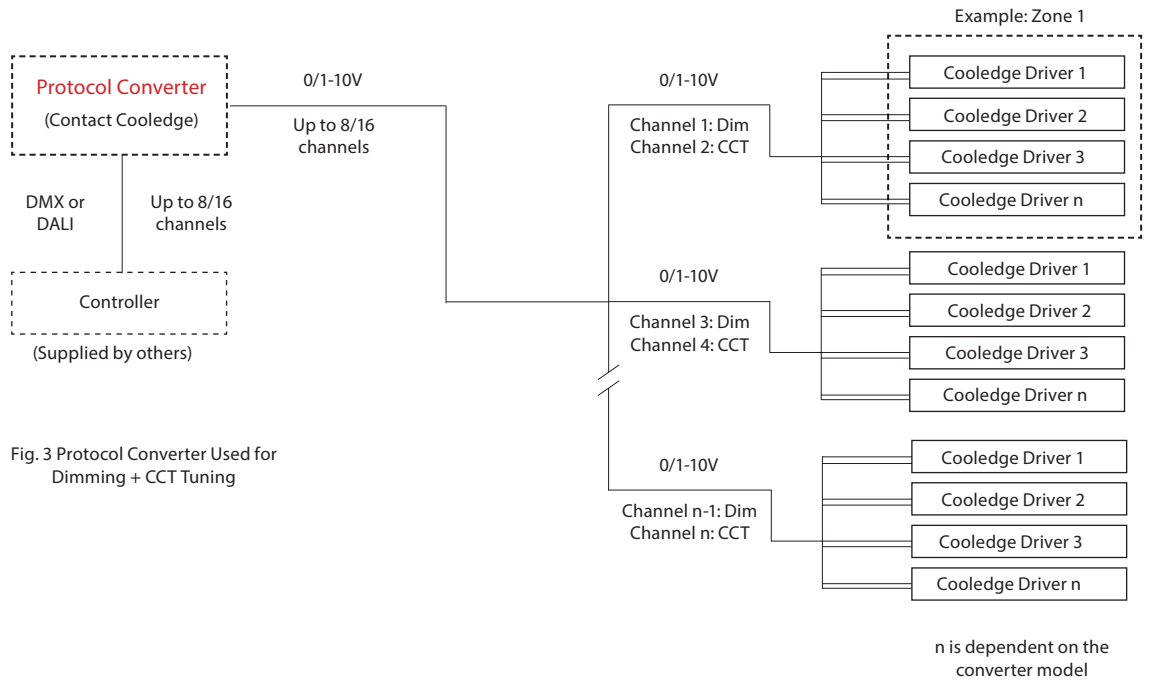

Fig. 3 Protocol Converter Used for Dimming + CCT Tuning

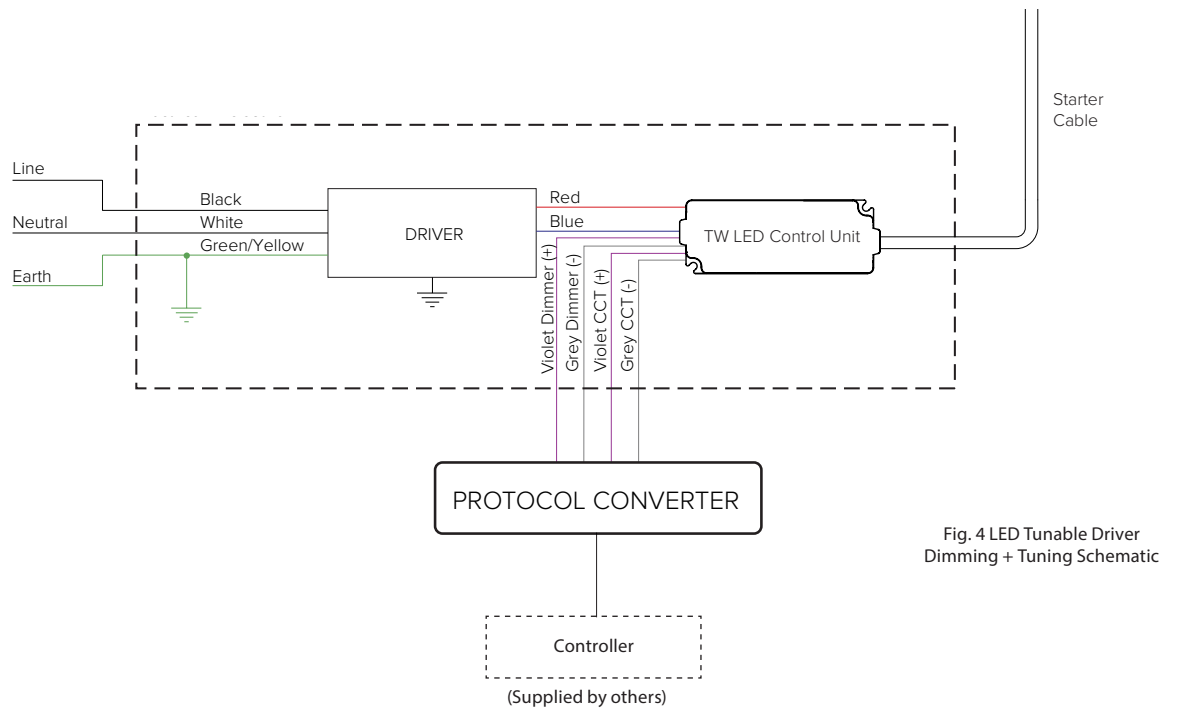

Fig. 4 LED Tunable Driver Dimming + Tuning Schematic